

# STERO MICROSCOPE HYM SERIES INSTRUCTIONS



## MANUAL

# Contents

1. Before use .....	1
2. Nomenclature .....	2
3. Assemblage .....	5
4. Operation .....	7
5. Configuration .....	13
6. Technical parameter.....	15
7. Troubleshooting .....	17

# 1 Before use

## **1-1** NOTICE

- 1) Microscope ought to be placed in a dry and clean place. Do not expose the microscope in the sun directly. Avoid high temperature and violent vibration.
- 2) As microscope is a precision instrument, handle with care, avoiding impact or abrupt movement during transportation.
- 3) To keep the image clear, do not leave fingerprints or stains on the surfaces of the lens.
- 4) Never turn the left and right focusing knob in the adverse direction at the same time, otherwise the microscope will be damaged.
- 5) Hold the camera with one hand for fearing of falling when you take the films out of the big camera.

## **1-2** MAINTENANCE

- 1) All lenses must be kept clean. Fine dust on the surface of the lens should be blown off with hand blower or wiped off gently with a soft lens tissue; Fingerprints or oil marked on it should be wiped off with a tissue moistened with a small amount of xylene or a 3:7 mixture of alcohol and ether.
- 2) Never use the organic solution to clean the other surface (especially the plastic surfaces). If necessary, please choose the neutral detergent.
- 3) Do not take the microscope apart for fearing that it is damaged.
- 4) After using, cover the microscope with the dust-cover provided and store it in a dry and clean place free from moisture to prevent rust.
- 5) To keep the performance of the microscope, please check it periodically. The detail can be gotten from the agent nearby.

## 2 Nomenclature

### 2-1 HYM-45B2

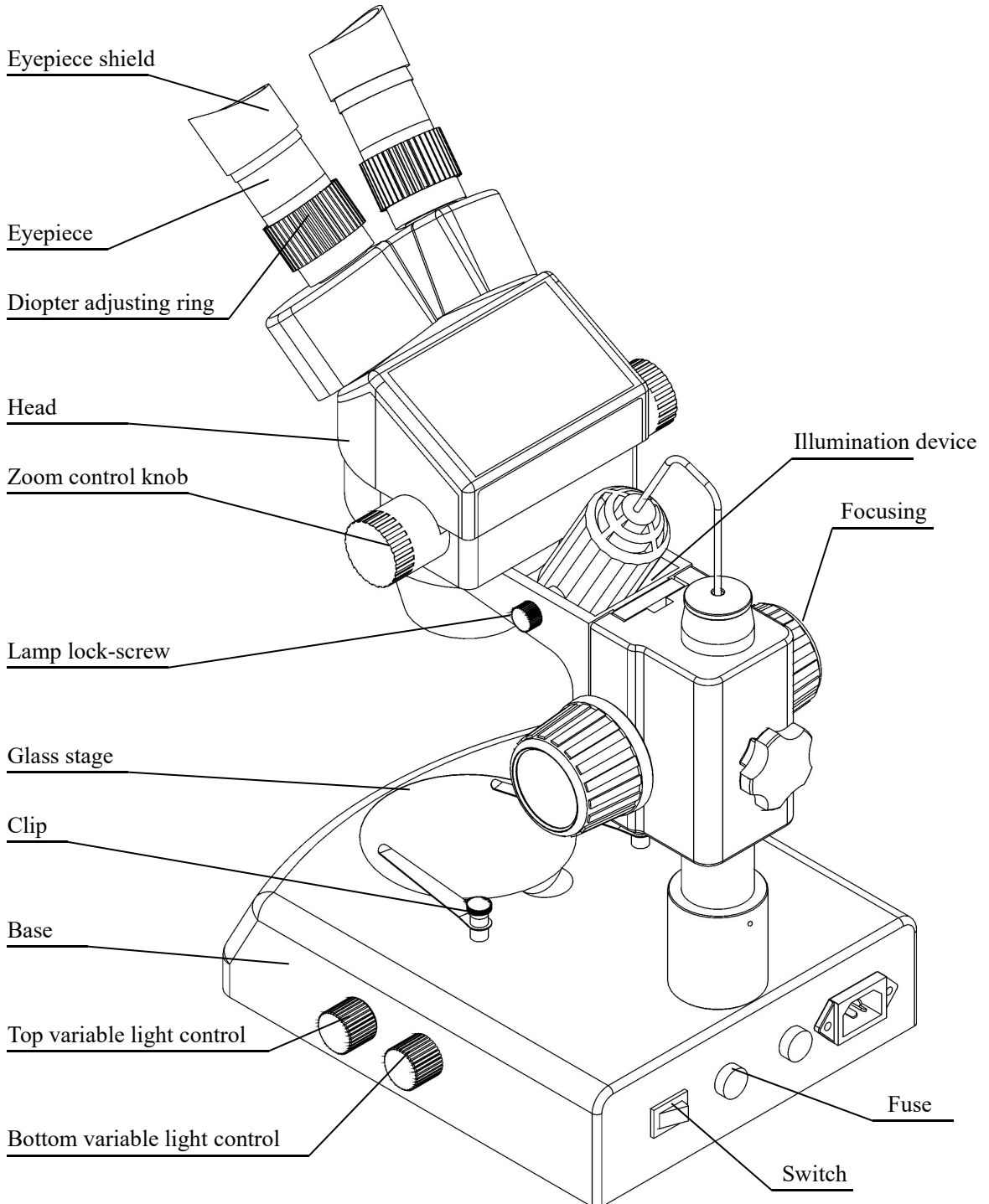

**2-2** HYMT2

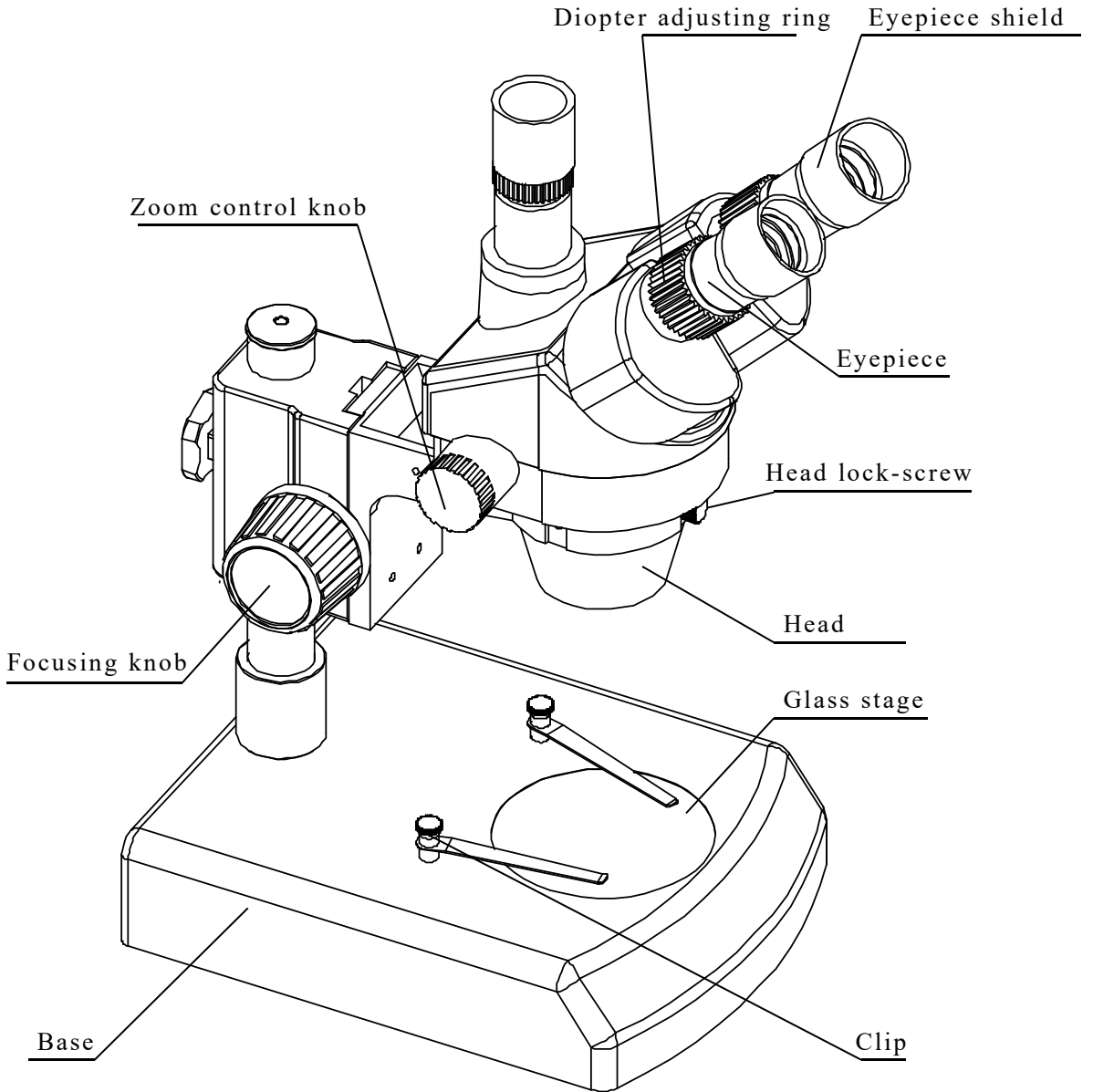

**2-2** *HYM-45V2*

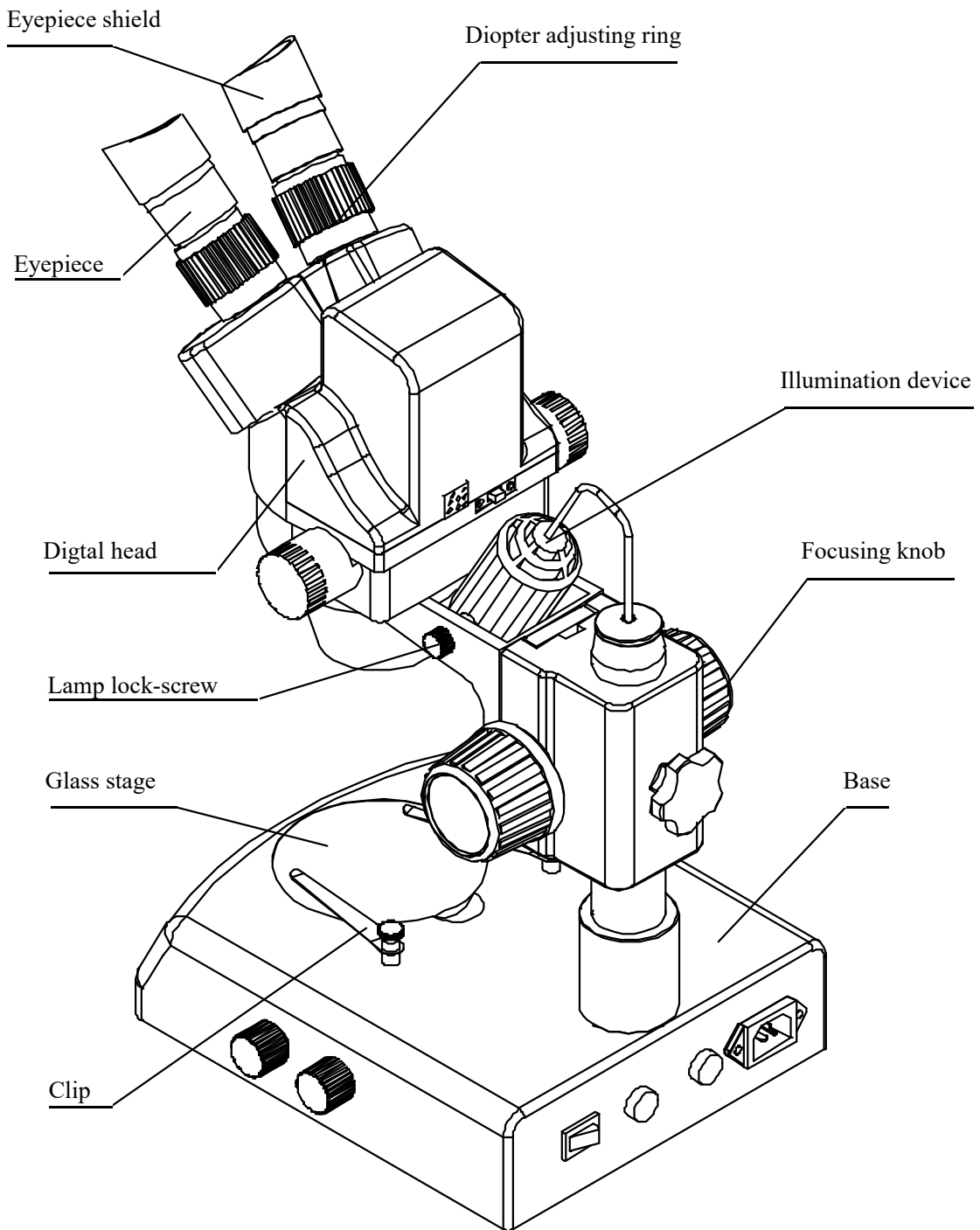

# 3 Assemblage

## 3-1 HYM-45B2

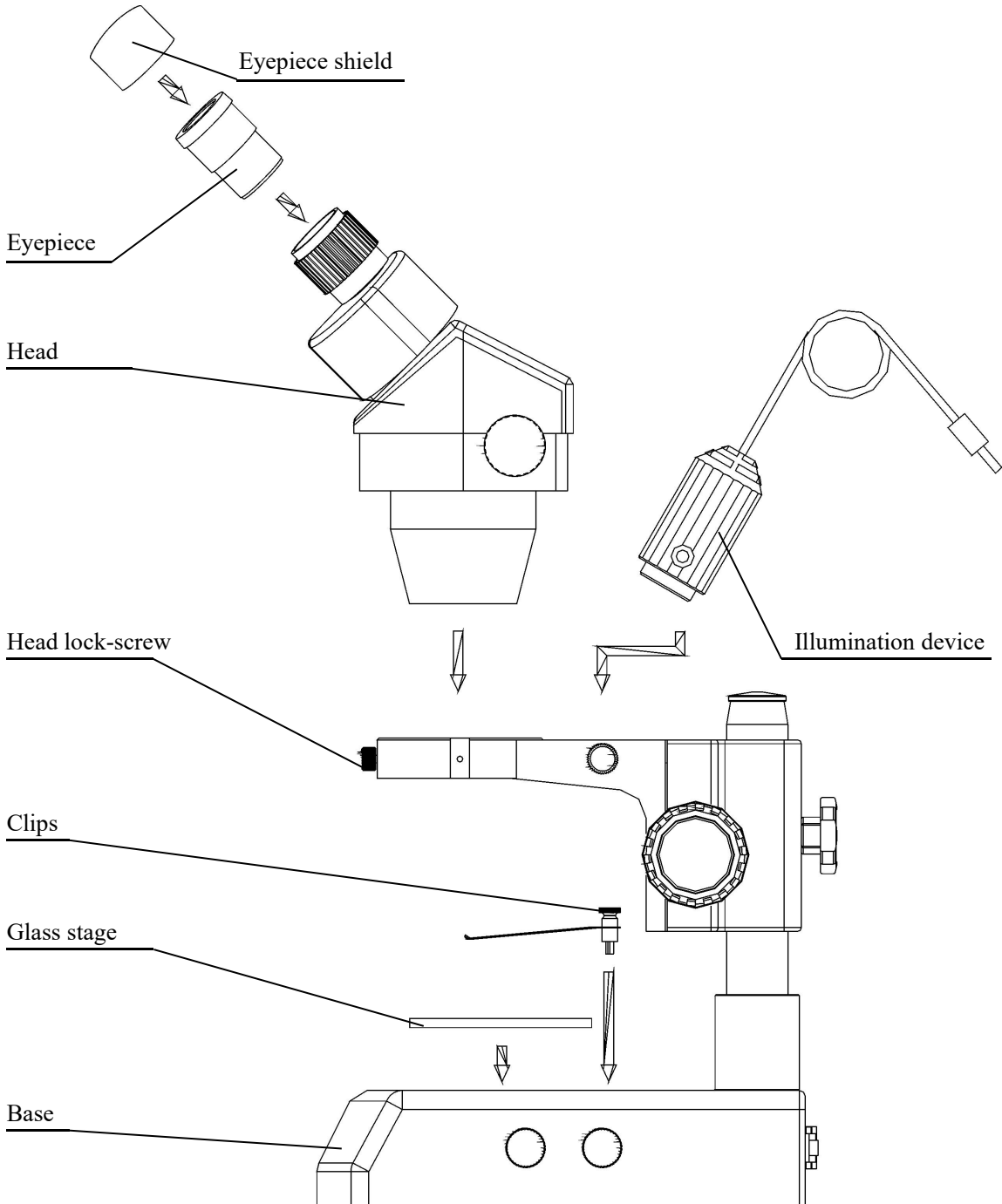

**3-2** *HYM-45T2+HYM-PH/HYM-CTV*

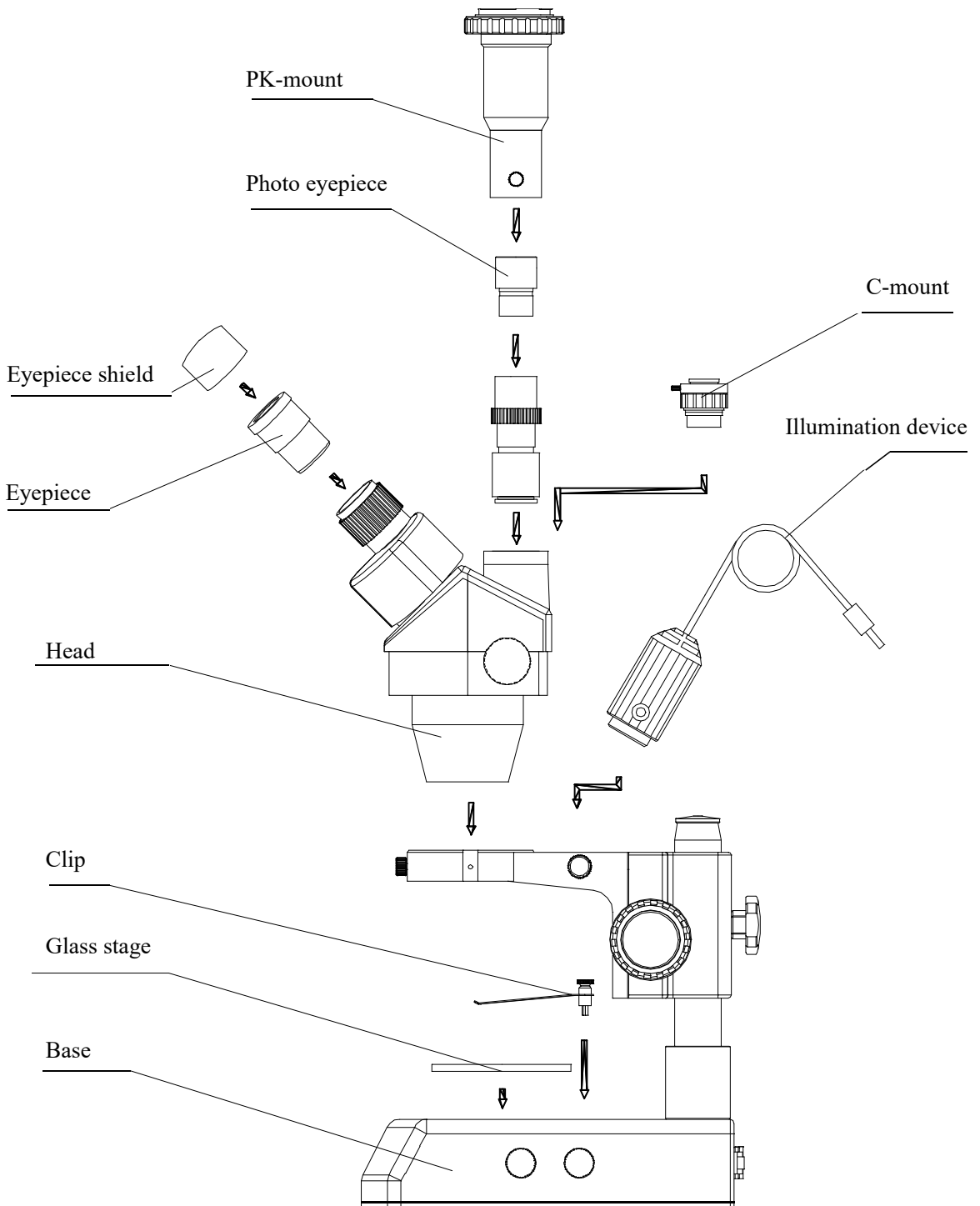



## 4 Operation

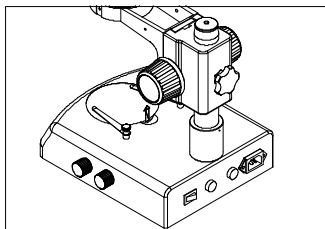

Fig.1

### **4-1** Use the glass stage

1) Press the glass stage on the sunken place then the other side of the glass stage will be lifted. (Fig.1)

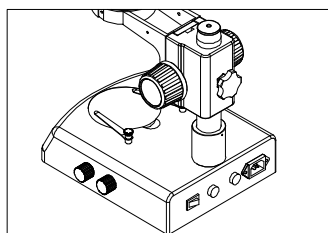

Fig.2

### **4-2** Adjust the degree of tightness of the focusing arm.

1) If you want to adjust degree of tightness of the focusing arm, you can hold one of the focusing knobs and turn another one to attain a suitable position. The degree of tightness relies on the direction to be turned. The clockwise direction is tight, otherwise, is loose.

2) The suitable position of tightness can make the adjustment more comfortable and prevent the focusing bracket from slipping down by its weight during the observation. (Fig.2)

### **4-3** Set the specimen slide

1) Set the specimen on the center of stage plate. If necessary, clamp the slide with the clips.

2) Turn on the light.

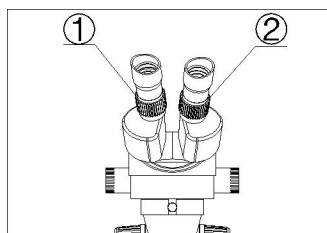

Fig.3

### **4-4** Adjust the specimen slide

1) Turn the zoom control knob to the maximum magnification.

2) Turn the diopter adjusting rings to the zero.

3) Observe the specimen through the right eyepiece and make the image clear by turning the focusing knob.

4) Rotate the zoom control knob to the minimum magnification.

5) Observe the specimen through the right eyepiece and make the image clear by turning the right diopter adjusting ring② .(Fig.3)

6) Redo the step(1),(3),(4)and (5) till the right adjusting ring is more precise.

7) Do the step (4) and make the image clear which is observed through the left eyepiece by turning the left diopter adjusting ring ①. (Fig.3)

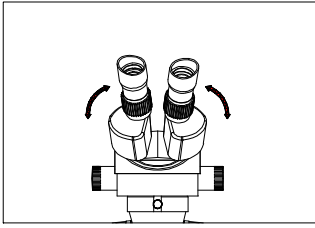

Fig.4

#### **4-5** *Adjust the interpupillary distance*

- 1) Adjust the prism housing along the direction of arrowhead of the Fig.4 till the observation is comfortable.

#### **4-6** *Use Eyepiece shields*

- 1) For user who does not wear glasses, hold the diopter-adjusting ring to prevent them from rotating and turn the eyepiece till the eyepiece shields fit the observer well.
- 2) For user who wears glasses, take the eyepiece shields off before observation

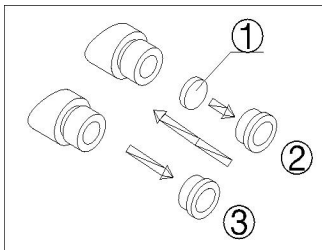

Fig.5

#### **4-7** *Mount and Remove the Optional Eyepiece Micrometer*

- 1) Turn and remove the mounting ring<sup>②</sup> from the eyepiece.(Fig.5)
- 2) Clean the eyepiece micrometer<sup>①</sup> and mount it to the mounting ring with the inscription side downward.
- 3) Gently twist the mounting ring with the eyepiece micrometer into the eyepiece till tightening<sup>②</sup> securely.
- 4) To remove the eyepiece micrometer, take down the mounting ring<sup>③</sup> by twisting and take out of the micrometer, and then wrap it.

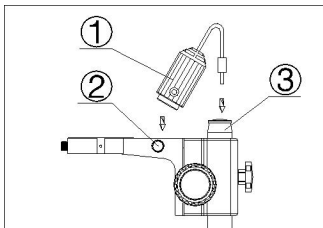

Fig.6

#### **4-8** *Install the illumination device*

- 1) Insert the illumination device<sup>①</sup> in the bracket with the protrudent side toward the lock-screw<sup>②</sup> and tighten the lock-screw. (Fig.6)
- 2) Put the plug into the socket of the pillar stand<sup>③</sup>.

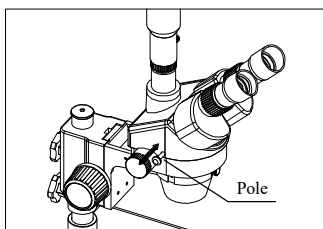
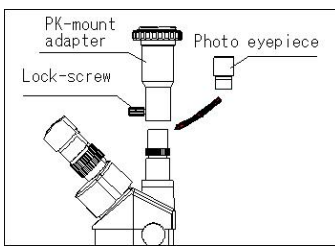

Fig.7

#### **4-9** *Choose the optical system*

- 1) You can alternate the binocular observation and video capture by pushing or pulling the pole. You can attain binocular observation by pushing the pole inside, or attain video capture by pulling it outside. No matter what optical system is chosen, push or pull the pole thoroughly.



#### **4-10** *Mount the photo eyepiece and the PK-mount*

## adapter

- 1) Put the photo eyepieces socket of the tri-ocular.
- 2) Connect the PK-mount adapter with the photo eyepiece, and then tighten the lock-screw. (Fig.8)

Fig.8

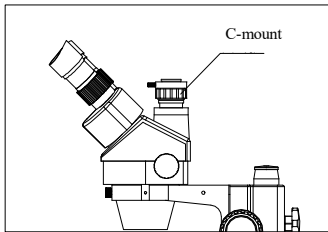

### **4-11** *Adjust the CTV*

- 1) Adjust the CTV to a suitable position by rotating C-mount.

**Note:** The range of the adjustment: 1~2mm in general.(Fig.9)

Fig.9

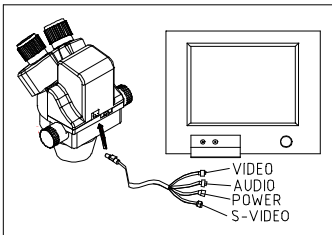

### **4-12** *Connect the Digital head With the Monitor or TV*

#### *set*

- 1) Plug one end of the PVA cable into the socket of the digital head. (Fig.10)
- 2) Plug the C-VIDEO or S-VIDEO of the PVA cable into the correct socket of Monitor (TV set).
- 3) Connect the 12V DC power with the power socket of the PVA cable.

Fig.10

### **4-13** *Appear the image on the Monitor or TV*

- 1) Connect the power supply and then turn on the Monitor or TV.
- 2) For the monitor, the connect sign model must be chosen (C-video or S-video) and for TV, the channel must be set to the video channel.
- 3) Pull the pole out and adjust the focusing knob and then the image will appear on the screen clearly.

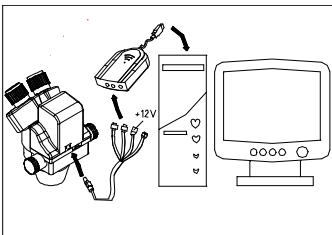

Fig.11

### **4-14** *Connect with the computer*

- 1) Plug one end of the PVA cable into the socket of the digital head.
- 2) Plug one of the C-VIDEO or S-VIDEO into the A/D board.
- 3) Plug the USB of the A/D board into the USB socket of the computer. (Fig.11)
- 4) If your computer is mounted capture card, you can connect the C-VIDEO or S-VIDEO with the computer directly.
- 5) Connect the 12V DC power with the power socket of the PVA cable.

### **4-15** *Appear the image on the computer*

- 1) Turn on the power supply and let the computer work.

- 2) Install the software and the driver of the A/D board. (If they have been installed, this step can be omitted.
- 3) Double click the icon of the software, and then the video window will appear. You can set the size of the window according to your linking
- 4) Draw out the pole and adjust the focusing knob, and then the image will appear on the computer screen clearly.
- 5) If no image or the image without color, it may be because the model of the input signal does not match the output signal of CCD or the model of C-VIDEO/S-VIDEO is not correct. The detail of operation refers to 《Software operation manual》 .

#### **4-16** *Appear the image on the computer and the Monitor synchronously*

- 1) Do step **4-12** and step **4-14** to connect the computer and the Monitor.
- 2) Operate step **4-13** and step **4-15**, we can make the image appear on the computer and Monitor at the same time.

#### **4-17** *Adjust the image*

- 1) Put the base, stand and digital head correctly, then fix the lock-screw tightly.
- 2) Put the object on the base stage.
- 3) Observe the object through the eyepiece and adjust the focusing knob to make the image of the object clearly.
- 4) Move the digital head or the object gently to adjust the image agreeing with observer.

#### **4-18** *Brief instruction for the software*

- 1) The program design of the software is up to date, and the Chinese/English interface can berth powerful delineation bar which be used much conveniently and rapidly. You can finish most of analyze work only to click the mouse.
- 2) Can afford many powerful area choosing tools which can analyse any area your linking at will, such as adjusting hue and image, dealing with mathematical morphology, image matching, texture analyse, character identify and so on.
- 3) Geometry character measuring function, automatically analyzing function such as slightness body, grain body, line body and so on. The outcome can be kept in data and can be made into

chart and so forth.

#### **4-19** *Use the white balance*

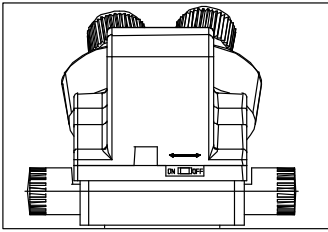

Fig.12

- 1) The CCD has auto white balance when the white balance switch is on “ON” .
- 2) Please put the switch on “ON” in general. Let the switch be “OFF” only in special, for example, observing the red cell, otherwise the color of red cell will be adjusted into white.
- 3) If you want to observe another single color, please let the switch be “ON” again when you finish the observation, and put the switch on “OFF” again after auto balance, or the color of the image will be distortion.(Fig.12)

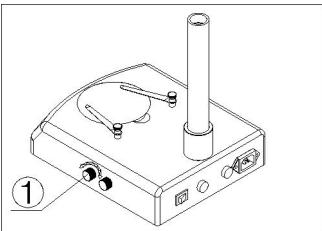

Fig.13

#### **4-20** *Adjust the brightness of the bottom light*

- 1) Turn the adjustable light knob① according to the sign marked on the base, along the clockwise the brightness will be added, otherwise it will be weakened. (Fig.13)

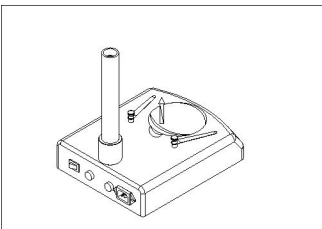

Fig.14

#### **4-21** *Replace the lamps*

- 1) Press the stage on the sunken place then the other side will be lifted. (Fig.14)
- 2) Take the lamp out of the jack.
- 3) Put a new lamp into the jack thoroughly.
- 4) Recover the stage plate. (Fig.15)

**Note:** ① Before replacing the lamps, turn off the power first.  
② Avoid violence while the lamp is plugged into the jack.

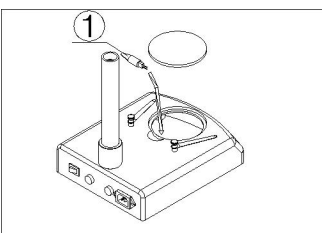
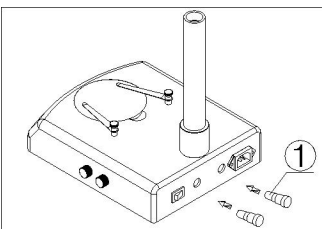

Fig.15

#### **4-22** *Replace the fuse*

- 1) Screw the fuse tube out with a screwdriver and then pull the fuse out of the tube①.
- 2) Renew the fuse and mount it in an adverse way. (Fig.16) Fig.16



## 5 Configuration

### 5-1 SZM series configuration

Configuration		Model							
Parts	Specification	SZM45B1	SZM45B2	SZM45B3	SZM45T1	SZM45T2	SZM45T3	SZM45V2	SZM45P2
Eyepieces	SZMEWh10X20	O	O	O	O	O	O	O	O
	SZMEWh15X15								
	SZMEHWh20X10								
Binocular	SZM7045	O	O	O					
Tri-ocular	SZM7045TR				O	O	O		
Digital head	SZM7045V							O	O
A/D board	W-A/D								O
PAV cable	W-RVB-PAV							O	O
Power adaptor	W-BW230-12-4.8							O	O
Software	Pholib3.0								O
Auxiliary objective	SZMAO0.5/165mm								
	SZMAO1.5/45mm								
	SZMAO2/30mm								
Focusing arm	SZMA1	O	O	O	O	O	O	O	O
Stand	SZMST1	O			O				
	SZMST2		O			O		O	O
	SZMST3			O			O		
	SZSTL1								
	SZSTL2								
Transformer	SZT1								
Epi-illuminator	SZML1		O	O		O	O	O	O
Hold for illuminator	SZFH1								
	SZPD1								
Photo device	SZMPH								
TV adapter	SZMCTV								
Gem clamp	S/ST-GC								
Dark field condenser Light	ST-30-2L-HJ-01								
Ring fluorescence	SZRL	O			O				
Box	Inside foam	O	O	O	O	O	O	O	O
	Outside carton								

**Note:** The items marked “O” included and others for option

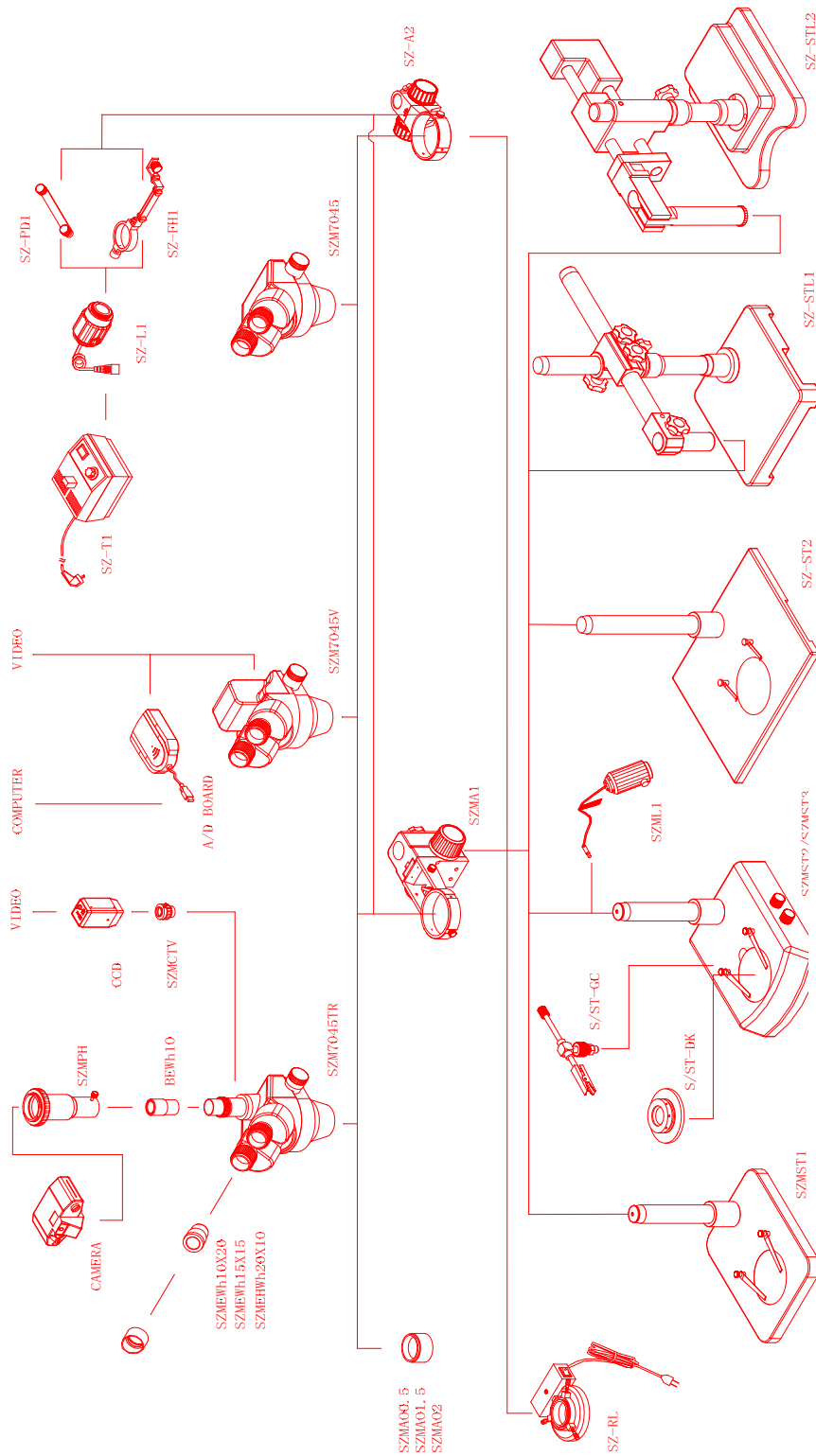

# 6 Technical parameter

## 6-1 HYM7045/HYM7045TR

Eyepiece	Standard configuration		Auxiliary objectives					
			0.5X		1.5X		2X	
	Working distance 100mm		Working distance 165mm		Working distance 45mm		Working distance 30mm	
	Magnification	Field of view	Magnification	Field of view	Magnification	Field of view	Magnification	Field of view
10X/20	7X	28.6	3.5X	57.1	10.5X	19	14X	14.3
	45X	4.4	22.5X	8.9	67.5X	3	90X	2.2
15X/15	10.5X	21.4	5.25X	42.8	15.75X	14.3	21X	10.7
	67.5X	3.3	33.75X	6.7	101.25X	2.2	135X	1.7
20X/10	14X	14.3	7X	28.6	21X	9.5	28X	7.1
	90X	2.2	45X	4.4	135X	1.5	180X	1.1

## 6-2 The base electronic specification of HYM series

Parts		Model	HYMST1	HYMST2	HYMST3
		Power supply	No	No	220V-50Hz、 110V-50/60Hz
Transformer	No	No	Input: 220/110VAC Output: 12V DC/45W	Input: 220/110VAC Output: 12V DC/45W	
Illuminator	Top light	No	12V/15W halogen lamp	12V/15W halogen lamp	
	Bottom light		12V/15W halogen lamp	220/110V、7W fluorescent lamp	



### 6-3 CCD specification

CCD Model Specification	NTSC	PAL
Pick-up Device	1/3 "	1/3 "
Vertical Resolution	450 TV line	450 TV line
Number of Pixels	(H) 768* (V) 494	(H) 712* (V) 582
Scanning System	525 lines, 60Field/Second	625lines, 50 Field/Second
White Balance	Can be switched between auto white balance and hand white balance	
Back light compensation	Auto	Auto
Signal/Noise ratio	More than 46db	More than 46db
Gamma Characteristic	0.45	0.45
Minimum illumination	3 Lux	3 Lux
Input voltage	12V DC (9V-14V)	12V DC (9V-14V)
Power consumption	1.85 or less	1.85W or less

- ★ Working distance is fixed regardless of the magnification factor.
- ★ Total mag.= Zoom mag. X Eyepiece mag. X Auxiliary objective mag.

$$\text{Diameter of field of view (mm)} = \frac{\text{Field number of eyepiece}}{\text{Zoom mag. X Auxiliary objective mag.}}$$

- ★ Photo adaptor mag.= Zoom mag.( X Auxiliary objective mag.) X Eyepiece mag.
- ★ TV adaptor mag.=Zoom mag. (Xauxiliary objective mag.) X C-mount TV adaptor middle
- ★ Field of video view is 83%
- ★ Total video magnification range is 18~117

# 7 Troubleshooting

The performance of the microscope can't be made fully because of unfamiliar using, this table will give some advices.

## 7-1 General troubleshooting

Trouble	Cause	Remedy
1、 Double images	Interpupillary distance is not correct	Readjust it
	Diopter adjustment is not correct	Readjust it
	Magnification of each eyepiece is not the same size	Mount the same size eyepiece
2、 Dirt appears in the field of view	Dirt on the specimen	Clean the specimen
	Dirt on the surfaces of eyepiece	Clean the surface
3、 Image is not clear	Dirt on the surfaces of the objectives	Clean the objectives
4、 Image is not clear while the focus changing	Diopter adjustment is not correct	Readjust the diopter
	Focus is not correct	Readjust the focus
5、 The focusing knob is not smooth	The focusing knob is too tight	Loosen it to a suitable position
6、 The image is obscure because of the head slipping down by itself during observation	The focusing knob is too loose	Tighten it to a suitable position
7、 Incision image appears in the field of view or of the video view	The pole is not in correct position	Pull or push it to the correct position
8、 The image on the monitor is not clear when the focusing knob is turned.	The focus of video is not correct	Readjust the focus of video to a correct position
9、 Eyes fell tired easily	Diopter adjustment is not correct	Adjust the diopter
	Brightness of light is not correct	Adjust the brightness
10、 Bulb does not work when the switch is on	No power supply	Check the connection with the power supply
	The bulb was not inserted correctly	Insert it correctly
	Bulb is wrong	Replace with a new one
11、 Bulb is burned out suddenly	Use the wrong bulb	Replace with a correct one
	The voltage is too high	Control the voltage Eg: use voltage regulator
12、 Brightness is not enough	Use a wrong bulb	Replace with a correct one
	The voltage is too low	Increase the input voltage
13、 The bulb flickers or the	The bulb will burn out soon	Replace with a new one

brightness is unstable	The bulb was not inserted correctly	Insert it correctly
------------------------	-------------------------------------	---------------------

## **7-2** *Video troubleshooting*

Trouble	Cause	Remedy
1、Incision image appears in the video view	The pole is not in correct position	Draw it to the correct position
2、Dirt appears in the video view	Dirt on the specimen	Clean the specimen
	Dirt on the surface of objective	Clean the surface
3、Image is not clear while the focus changing	The image is not clear in the high magnification	Readjust the high magnification
4、No image on the TV screen	The draw pole is not in correct position	Draw it to the correct position
	Objective cover is not open	Open it
	TV is not on Video channel	Choose the correct one
5、No image on the Monitor	Connection is not correct	Reconnect the circuit
	Objective cover is not open	Open it
	The input signal does not accord with the signal be chosen on the Monitor	Choose the correct signal model
6、The software run slowly or the window of the view does not come out	12V DC power does not be connect	Connect the 12V DC power
	No input signal of A/D board	Reconnect the C-Video or S-Video signal
	The input signal does not accord with the signal which is chosen in the driver of the A/D board	Choose the correct signal model which match the input signal
7、The image is not correct on the view window	The CCD model chosen in the driver of the A/D board does not accord with the real CCD	Choose the correct CCD model